

gala

Reference G3931500
Description Built-in basin mixer
Collection BALANCE



TECHNICAL SPECIFICATIONS

Built-in basin mixer with 22 cm spout



Eco-friendly cartridge with two-step opening

Ceramic discs cartridge $\varnothing 40$ mm

Anti-vandal aereator with limescale protection and integrated filter against particles

Installation with up-down valve

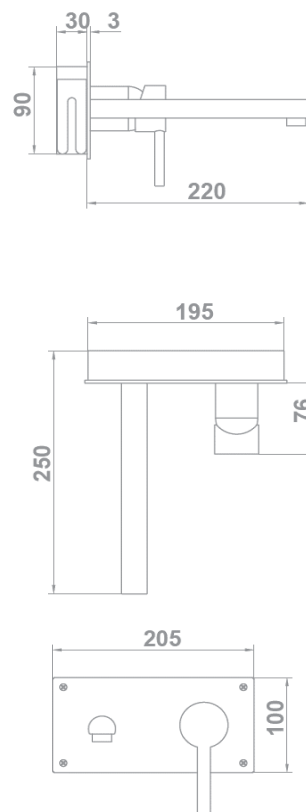

FLOW RATE

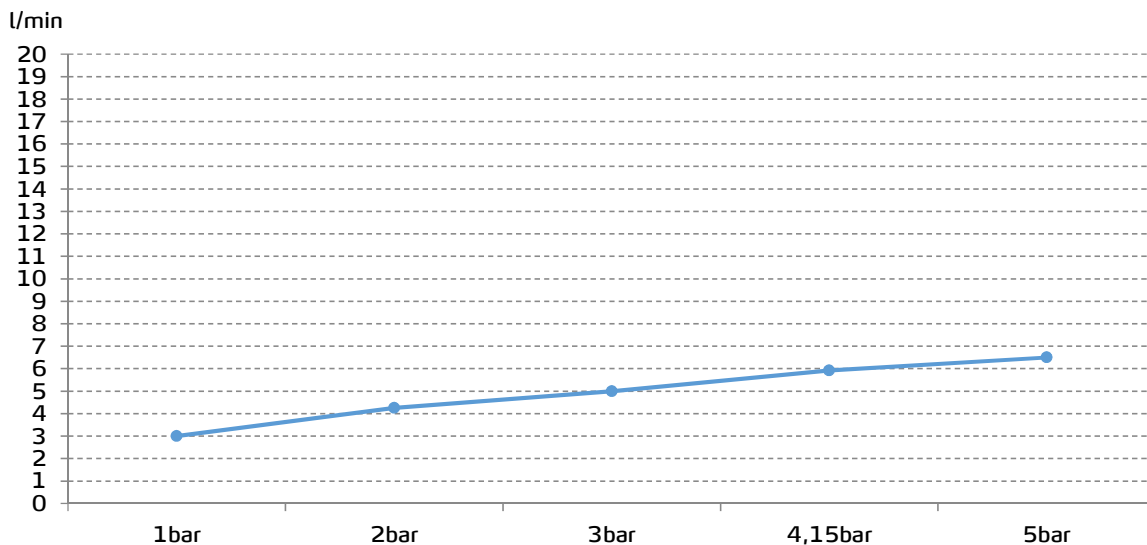

Data measured in maximum flow position with mixed water